

OWLG/OWLS Series

QUICK START GUIDE



OWLG

OWLS

OWLG/OWLS Series - Laser distance sensors

- Ultra compact design
- Measuring ranges up to 550mm
- Versions with laser line for rough surfaces (OWLS only)
- Measuring rate up to 1.1 kHz
- Robust metal housing with protection class IP67

OWLG

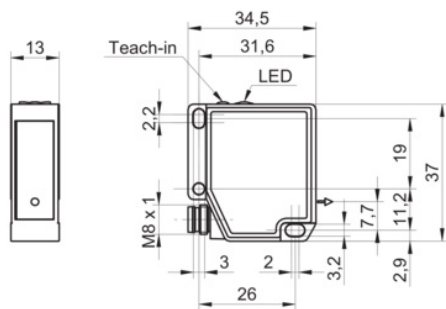

OWLS

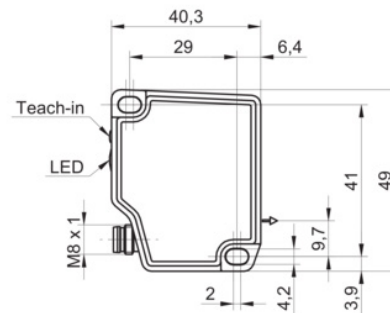

OWLG/OWLS Series

INSTALLATION INSTRUCTIONS

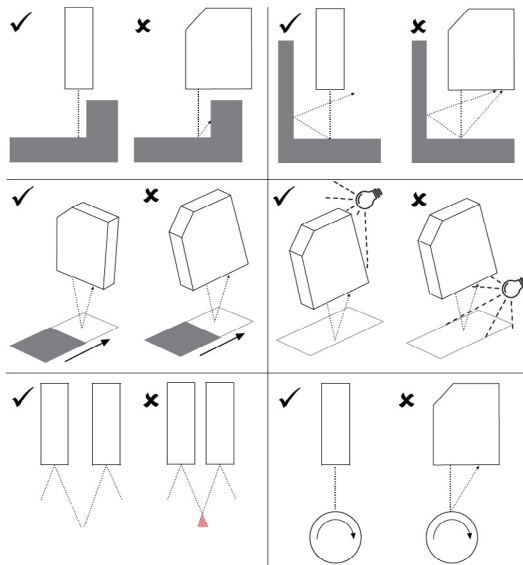

CONNECTION DIAGRAM

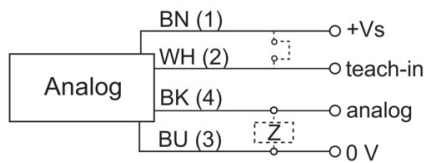

1	BN	Brown
2	WH	White
3	BU	Blue
4	BK	Black

PIN ASSIGNMENT

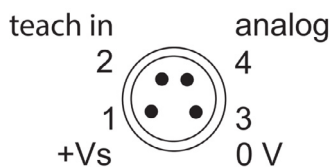

1	+Vs
2	teach in
3	0 V
4	analog

If the teach-in line is not used, set it to 0 V.

Operating voltage range: +Vs = 12 - 28 VDC.

Disconnect power from the system before reconnecting the device. Power supply according to UL 1310, Class 2 or external fuse protection by a UL recognized or listed fuse with max. 100W/Vp or max. 5 A under 20V. Note on electromagnetic compatibility: Shielded connection cable recommended. Ground the cable shield on both sides, over a large area, and ensure potential equalization.

LASER



Depending on the version, the product has laser class 1 or laser class 2 (see data sheet). The following applies to laser class 2

- Laser radiation!
- Do not look into the laser beam.
- Class 2 laser product.

OWLG/OWLS Series

INSTRUCTIONS FOR APPROPRIATE USE

This product is a precision device and is used to detect objects, the acquisition of physical measured units and for the evaluation of measured values for output in form of electrical signals for the higher-level system. Unless this product is specially labeled, it must not be used for operation in potentially explosive atmospheres.

MEASURING FIELD

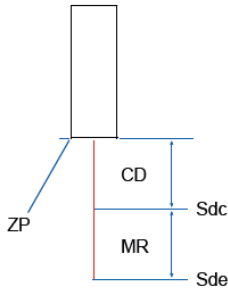

ZP	Zero position
Sdc	Start of measurement range
Sde	End of measurement range
D	Blind region
MR	Measurement range

SENSOR-LEDS

POWER	Green - Illuminated	Sensor ready for operation
ALARM	Red - Illuminated	No valid signal within the measurement range
ALARM	Red - Blinking	Critical signal quality

MOUNTING

- For measurement objects with shiny surfaces: Tilt the sensor 6° to 10° to the side so that the light reflecting directly from the surface does not hit the sensor's receiver.
- For mounting, use at least 1 tooth lock wash to break up the paint layer of the sensor.

	OWLG	OWLS
Screws	2x M3	2x M4
Torque	0.6 Nm ±10 %	1 Nm ±10 %

PARAMETERIZING THE SENSOR

The following options are available for parameterizing the sensor:

- Teach-in line
- Teach button on the sensor

The teach button is automatically deactivated after 5 minutes. Parameterization via the teach line takes place analogously to parameterization with the teach button. Connect the teach-in line to +Vs for this purpose. The teach-in line is not blocked and is also available during operation. The parameterization via the teach button is described below.

OWLG/OWLS Series

TEACHING AN ANALOG MEASUREMENT FIELD

Shifting the limits of the analog measuring field allows you to adjust the resolution of the analog output. By narrowing the analog measuring field, smaller distance changes can be displayed.

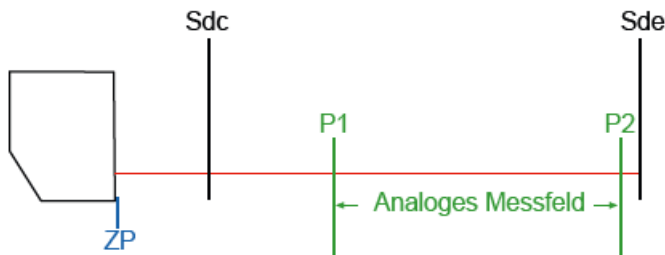

Instruction:

- Briefly press the Teach button.
 - Red LED lights up (teach button is active).
If the red LED does not light up, restart the sensor or connect the teach-in line to +V for 15 seconds.
- Press and hold the teach button for 5 seconds.
 - Red LED blinks.
- Teach min. limit of analog measurement range (distance at which min. voltage or min. current is displayed): Place the measurement object on position 1 (P1) and briefly press the teach button.
 - Red LED lights up for 3 seconds and then continues to blink evenly.
- Teaching in the max. limit of the analog measurement range (distance at which max. voltage or max. current is displayed): Place the measurement object on P2 and briefly press the teach button.

Result:

 - Teach-in ok: Red LED lights up for 3 seconds and then blinks briefly. Afterwards, the sensor goes back to operating mode.
 - Teach-in not ok: Red LED blinks for 5 seconds. Afterwards, the teaching process is aborted without the parameterization being performed.

Notice:

The characteristic curve of the analog output can be inverted by the teaching process (negative gradient). To do this, teach the maximum distance for P1 and the minimum distance for P2.

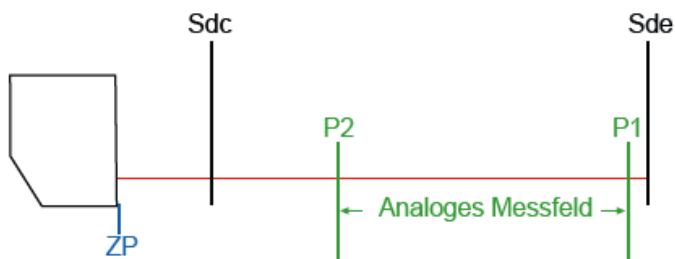

RESETTING TO FACTORY SETTINGS

Instruction:

- Briefly press the Teach button.
 - Red LED lights up (teach button is active).
If the red LED does not light up, restart the sensor or connect the teach-in line to +V for 15 seconds.
- Press and hold the Teach button for 15 seconds (after 5, the red LED will start blinking, but do not release the Teach button).

Result:

 - Teach-in ok: Red LED lights up. Afterwards, the sensor goes back to operating mode.
 - Teach-in not ok: Red LED blinks for 5 seconds. Afterwards, the teach process is aborted without the parameterization being performed.

OWLG/OWLS Series

TROUBLESHOOTING

- **Error:**
The sensor does not start even though the power supply is connected. The LEDs of the sensor are switched off.
- **Possible cause:**
The voltage supply is interrupted. A short circuit has occurred.
- **Remedy:**
Check the electrical connection of the sensor according to the connection diagram.

- **Error:**
A valid measurement cannot be recorded, the LED is on in red, and the laser is switched on.
- **Possible cause:**
The measuring object is outside the measuring range (MR). Refer to the data sheet for the measuring range for your sensor version.
- **Remedy:**
Move the measurement object into the measurement range.

- **Error:**
The measurement results are incorrect.
- **Possible cause:**
The direct reflection of the laser hits the receiver of the sensor. This happens especially on shiny surfaces.
- **Remedy:**
Tilt the sensor sideways so that the direct reflection of the laser does not hit the receiver of the sensor.

- **Error:**
The measured value shows faulty, erratic behavior.
- **Possible cause:**
Too much ambient light is entering the field of view of the sensor receiver. This leads to disturbing peaks on the receiver.
- **Remedy:**
Reduce the ambient light (e.g. by using a cover).

FACTORY SETTINGS

DESCRIPTION	VALUE
Min. limit of analog measurement range	Sdc
Max. Limit of the analog measurement range	Sde

MAINTENANCE

The sensor is maintenance-free. No special maintenance is required. Regular cleaning and regular checking of the plug connections is recommended.